

SRE06 FLOATING/MODULATING THERMOSTAT

DESCRIPTION

SRE06 floating/modulating thermostat is mainly used in central air-conditioning and heating system. It works with TSC series temperature sensor. It provides temperature control for central air-conditioning fan coil cool / heat motorized valves or other actuating mechanism in proportional and integral way. It can also control the fan blower of fan coil units and adjust the fan speed. When the electronic thermostat is turn off or power on, it can output a return signal to make the motorized valves or other actuating mechanism return.



CHARACTERISTICS





- ◆ Auto-return function when turn off or power on.
- ◆ Power surge and instant pulse protection.
- ◆ Overtime protection function.
- ◆ Large LCD shows the ambient temperature, state and air volume.
- ◆ With system switch and fan speed switch.
- ◆ Inside or outside long-distance temperature sensitive element (NTC thermistor)
- ◆ Cool/Heat shift: clockwise or anti-clockwise direction signal output (summer or winter)
- ◆ With ABS fireproof plastic, compliance with UL-94 standard.
- ◆ With flexible installation and convenient wire-connection.

TECHNICAL DATA

NAME	SRE06F		SRE06P	
	POWER SUPPLY	AC24V	AC220V/230V	AC24V
OUTPUT	AC24V 1A	AC220V/230V 1A	DC0-10V 10mA	DC0-10V 5mA
POWER CONSUMPTION	0.6VA (without load)	5VA (without load)	0.6VA (without load)	5VA (without load)
FAN VOLTAGE	AC24V (2A)	AC220V/230V (2A)	AC24V (2A)	AC220V/230V (2A)
CONTROL PRECISION	±0.5°C (±1°F)			
CONTROL RANGE	10°C - 30°C or 50°F - 86 °F			
RETURN TIME	≥150s or ≥300s (for optional)		---	
OVERTIME CUT OFF	Total runtime for valve in the same direction ≥150s (≥300s), turns into overtime protection state.		---	
SENSITIVE ELEMENT	NTC thermistor 10K Ω (when at 25 °C)			
WORKING TEMPERATURE	0 ~ 55 °C/32 °F ~131 °F			
STORAGE TEMPERATURE	-10 ~ 60 °C/14 °F ~140 °F			
AMBIENT HUMIDITY	90% RH maximum			

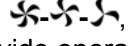
INSTRUCTION

1. **Cool/heat shift:** When power on (power supply switch at “●”), the thermostat will self-check, and then make the valve run for 150 seconds (or 300 seconds) continuously towards the closing end. When it finishes operation, the system will enter into turn off state. When the power supply switch moves to “❄”, the LCD will show the cooling state symbol “❄”, the action signal will output forward; when it moves to “☀”, the LCD will show the heating state symbol “☀”, the action signal will output backward. When it moves to “●”, the LCD will shut off, the valve will run for 150 seconds (or 300 seconds) continuously towards the closing end, then the system will be shut off.

- Fan:** When the thermostat is in cooling or heating state, move the fan switch , the LCD will display corresponding air volume symbol. The terminals will output power and provide operating power for the fan. If the thermostat isn't connected to the fan, only  or  can be shown on the LCD. The symbol  can only be shown when the thermostat is connected to fan completely and correctly.
- Temperature setting:** When user presses Δ (increase) / ∇ (decrease) button, LCD display temperature setting will show increase or decrease accordingly. The increase/decrease rate is $1^{\circ}\text{C}/1^{\circ}\text{F}$. The adjusting range is $10\sim 30^{\circ}\text{C}/50\sim 86^{\circ}\text{F}$. When user stops pressing the button for over 5 seconds, the thermostat will change the setting temperature data in its memory, and then the LCD shows the ambient temperature. (You can choose the initialization setting point as $22^{\circ}\text{C}/72^{\circ}\text{F}$, $23^{\circ}\text{C}/74^{\circ}\text{F}$ or $25^{\circ}\text{C}/77^{\circ}\text{F}$.)
- Built-in/external sensor:** When built-in NTC thermistor is used, the jumper J3 should be put to "Int" position. If the external NTC sensor is used, the jumper J3 should be put to "Ext" position.
- The temperature range shown on the LCD is $0^{\circ}\text{C} \sim 40^{\circ}\text{C}$ or $32^{\circ}\text{F} \sim 99^{\circ}\text{F}$.

WIRING DIAGRAM

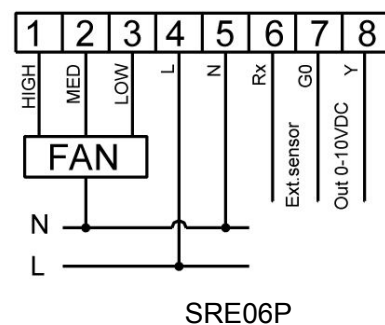
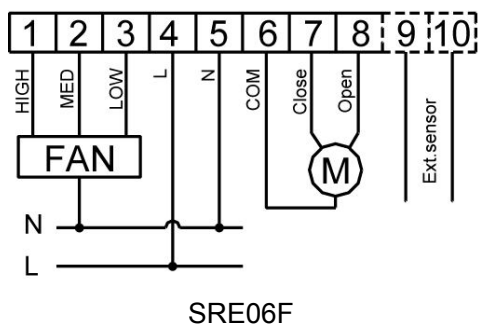

INSTALLATION INSTRUCTION

